



Description

The Crestron® CS-SHADE-ROLLER-CABLEGUIDED is a shade accessory that allows shade fabric to travel at up to a 20° angle. The cable guided shade kit works alongside virtually any Crestron Architectural or Decor series shade mounting bracket and can be installed on a wall, window jamb, or ceiling.

Additional Resources

Visit the product page on the Crestron website (www.crestron.com) for additional information and the latest firmware updates. Use a QR reader application on your mobile device to scan the QR image.



Shade Bracket Installation

Install the shade brackets in accordance to the order sheet, the "Cable Bracket Mounting Guidelines" on page 2, and their Installation Guide. For bracket installation details, refer to its Installation Guide at www.crestron.com/manuals.

CAUTION: There is risk of personal injury and equipment damage if the shade or associated parts fall during installation. Use care when installing. Use proper mounting hardware (e.g., screws or bolts) for the mounting surface when securing the brackets to the surface.

Cable Bracket Installation

To install the CS-SHADE-ROLLER-CABLEGUIDED, the bottom anchor and the top anchor must be installed. Also, the cable must be prepared and installed.

NOTE: Use the included screws on walls or jambs that are made with wood or metal blocking. These screws should not be used for hollow drywall or masonry installations. It is the responsibility of the installer to ensure that a secure mounting method is used.

NOTE: Ensure that no objects interfere with the shade travel (e.g., window hardware).

NOTE: Cables must be parallel with each other and with the shade fabric travel. They should not be more than 1/2 in (13 mm) out of parallel.

Install the Bottom Anchor

The bottom anchor can be secured to the window sill or floor or the window jamb. Two bottom anchors exist. The bottom anchor for sill or floor installation allows the cable to exit through the top of the bottom anchor. The bottom anchor for the jamb installation allows the cable to exit through the side of the bottom anchor.

Sill or Floor Installation

To install on the sill or floor:

1. Secure the anchor nut to the window sill using the provided screw.

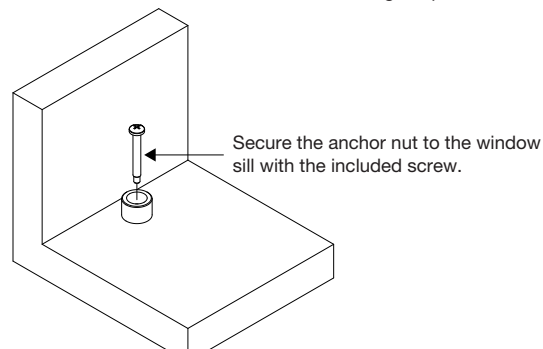

2. Feed the cable through the anchor housing and then tighten to the anchor nut.

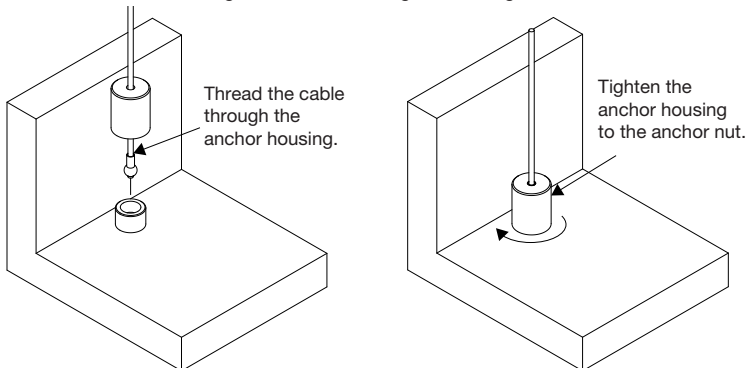

3. Repeat steps 1 and 2 for the other bottom anchor.

Jamb Installation

To install on the window jamb:

1. Secure the anchor housing to the window jamb using the provided screw.

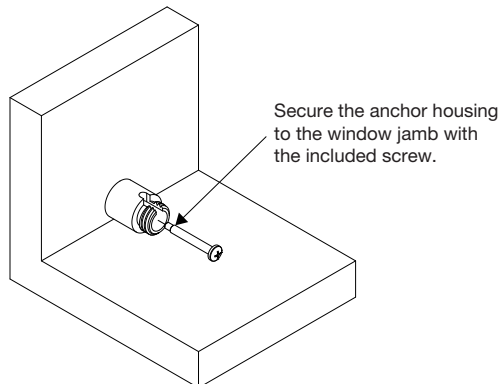

2. Insert the cable into the anchor housing and tighten the anchor cover.

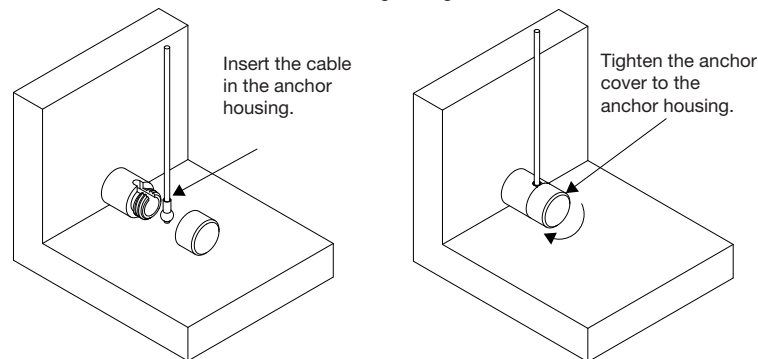

3. Repeat steps 1 and 2 for the other bottom anchor.

Install the Top Anchor

The top anchor can be secured to the window header or ceiling or to the window jamb. The top anchor for window header or ceiling mount applications consists of a cable block that is secured to a mounting bracket. The mounting bracket is secured to the window header or ceiling. The window jamb mount applications consist of only a cable block that is secured to the window jamb.

Header or Ceiling Installation

Use the included screws to secure the mounting bracket to the window header or the ceiling. The mounting bracket installation location is determined by the guidelines shown on the following page.

NOTE: If necessary, this bracket can be secured to the window jamb.

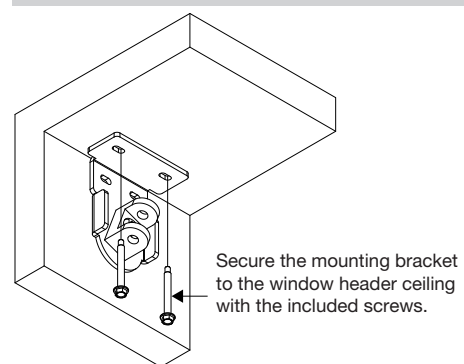

Jamb Installation

Use the included screw to secure the cable block to the window jamb. The mounting bracket installation location is determined by the guidelines shown on the following page.

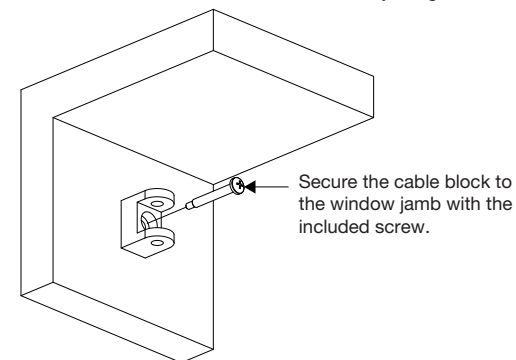

Prepare and Install the Cable

To attach the upper section of the cable to the top anchor, the threaded rod must be attached to the cable block, the cable must be cut to length, and the cable must be secured to the threaded rod.

1. Insert the threaded rod through the cable block and secure the threaded rod with the included lock-nut. Ensure that 1/2 in (13 mm) of the threaded rod extends past the top of the cable block.

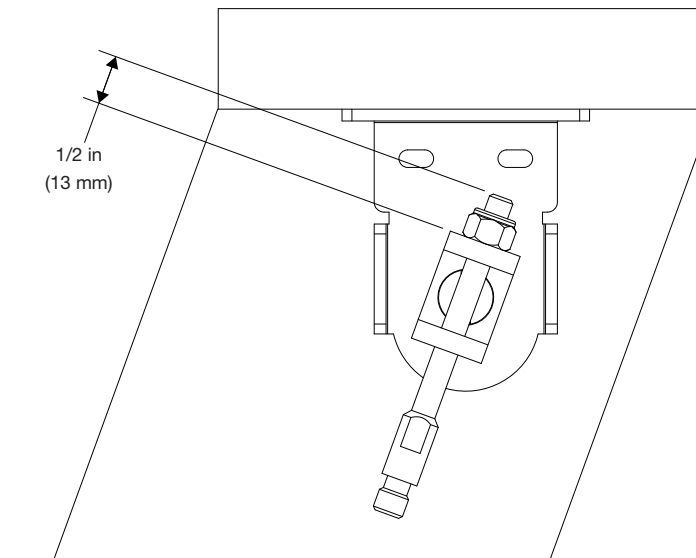

2. Feed the cable through the cable grip housing and then through the cable grip.

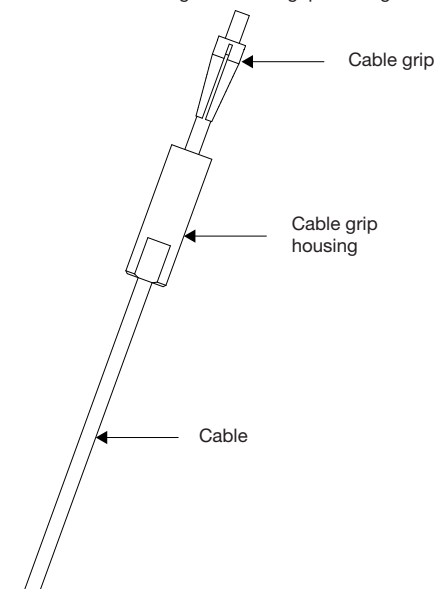

3. Bring the loose end of the cable to the top anchor and ensure that there is no slack in the cable. Using cable cutters capable of cutting 1/8 in (3 mm) stainless steel cable, cut the cable in line with the ridge indicated on the threaded rod. Slight fraying when the cable is cut is acceptable as long as the cable grip and cable grip housing can fit into the threaded rod.

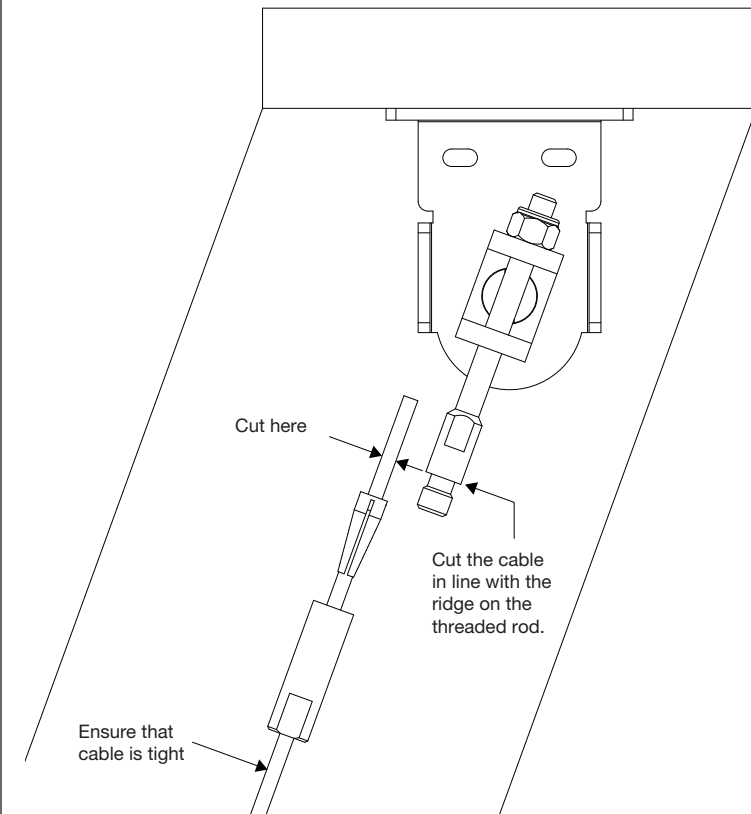

4. Remove the lock-nut from the threaded rod and remove the threaded rod from the cable block.
5. Slide the cable grip housing over the cable grip and near the end of the cable.
6. Ensure that the cable does not slip out of the cable grip housing, and tighten the cable grip housing to the threaded rod. Excess cable fits in the threaded rod. Use torque wrenches to ensure that 23 ft-lb of torque is applied to the cable grip housing.
7. Insert the threaded rod into the cable block, and tighten the lock-nut.
8. Tighten the lock-nut to adjust the cable tension. Apply about 5 pounds of force to the middle of the cable and verify that the deflection does not exceed the following:
 - 1/2 in (13 mm) for shades smaller than 60 x 60 in (1524 x 1524 mm).
 - 1 in (26 mm) for shades larger than 60 x 60 in (1524 x 1524 mm).

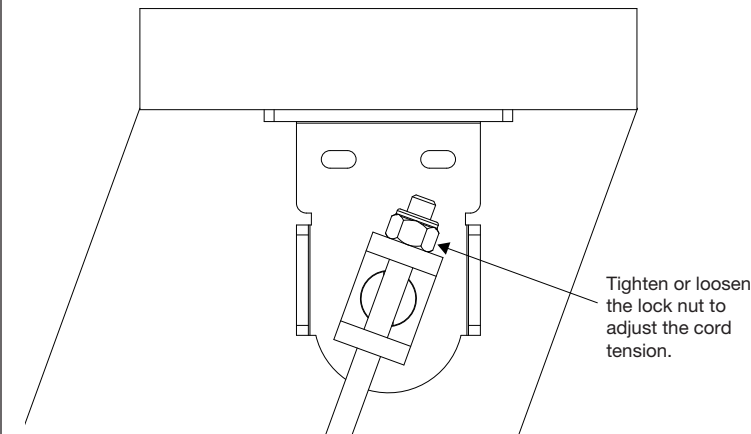

Secure the Hembar to the Cables

To secure the hembar to the cables, twist the hembar to allow the cables to enter the slots on the end cap. Rotate the hembar to secure the hembar to the cables.

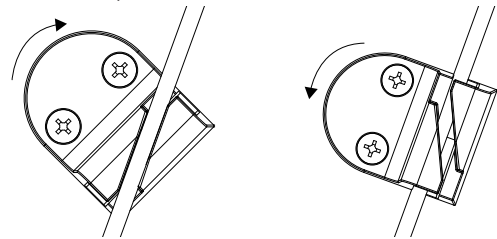

Test the Shade

WARNING: Care has been taken to ensure that the shade is properly balanced. Prior to initial operation, please confirm that the brackets have been adjusted so that the shade hangs level and plumb and that the cables are parallel to each other and the shade fabric. Upon startup, run the shade fabric all the way down and check for plumb. Observe the shade closely as it rolls up. If the shade fabric begins to sag at any point, stop immediately and take the appropriate action to ensure the shade tracks properly. To prevent damage to the fabric, do not leave the shade unattended during the first few cycles of operation. Failure to follow these instructions may result in damage to the edge of the fabric, which is not covered by the warranty.

NOTE: Before using the CS-SHADE-ROLLER-CABLEGUIDED, ensure the shade motor is using the latest firmware. Check for the latest firmware at www.crestron.com/firmware. Load the firmware onto the device using Crestron Toolbox™ software.

Situations that may cause fabric sag:

- The shade is not perfectly level.
- The shade may bump into objects while traveling up or down.
- The HVAC ductwork is blowing on the shade, or air is coming in through a window.
- A foreign object is stuck to the shade fabric (e.g., tape, bugs, dust, etc.).

How to prevent fabric sag:

- Use the leveling features built into the shade brackets to ensure the shade is level. If the bracket adjustment is not enough to compensate, use a shim to level the system.
- Ensure that no obstructions exist near the window area that the shade could bump into while traveling (e.g., latches and cranks).
- Direct HVAC airflow away from the shade, and ensure that windows are closed while operating the shade.
- Lower the shade all the way down to the bare tube (the shade will need to be placed into Limit Setup mode to allow the shade to travel below its lower limit). Inspect the front and back of the shade to ensure that no foreign objects are stuck to shade fabric.

If the shade is still telescoping, it can be re-shimmed by applying a small (1" x 1") piece of tape to the end of the tube that the fabric should move toward. If the fabric is telescoping to the left, place a piece of tape on the right side of the tube. If the fabric is telescoping to the right, place it on the left side. Ensure that the tape is placed on the bare tube for best results. The shade must be rolled all the way down past its lower limit. To do this, place the shade motor into Limit Setup mode.

Cable Bracket Mounting Guidelines

When determining mounting locations for the shade brackets and CS-SHADE-ROLLER-CABLEGUIDED parts, use the following dimension drawings as a guideline to ensure proper clearance.

Architectural Bracket Measuring guidelines

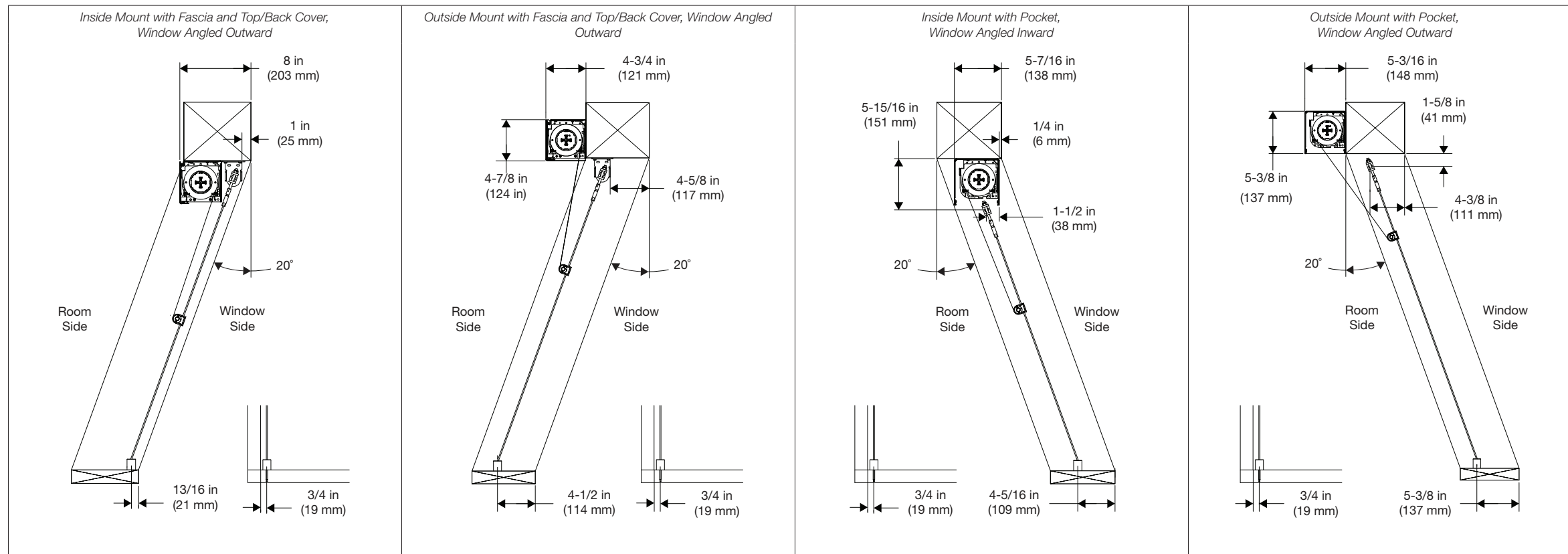

Decor Bracket Measuring guidelines

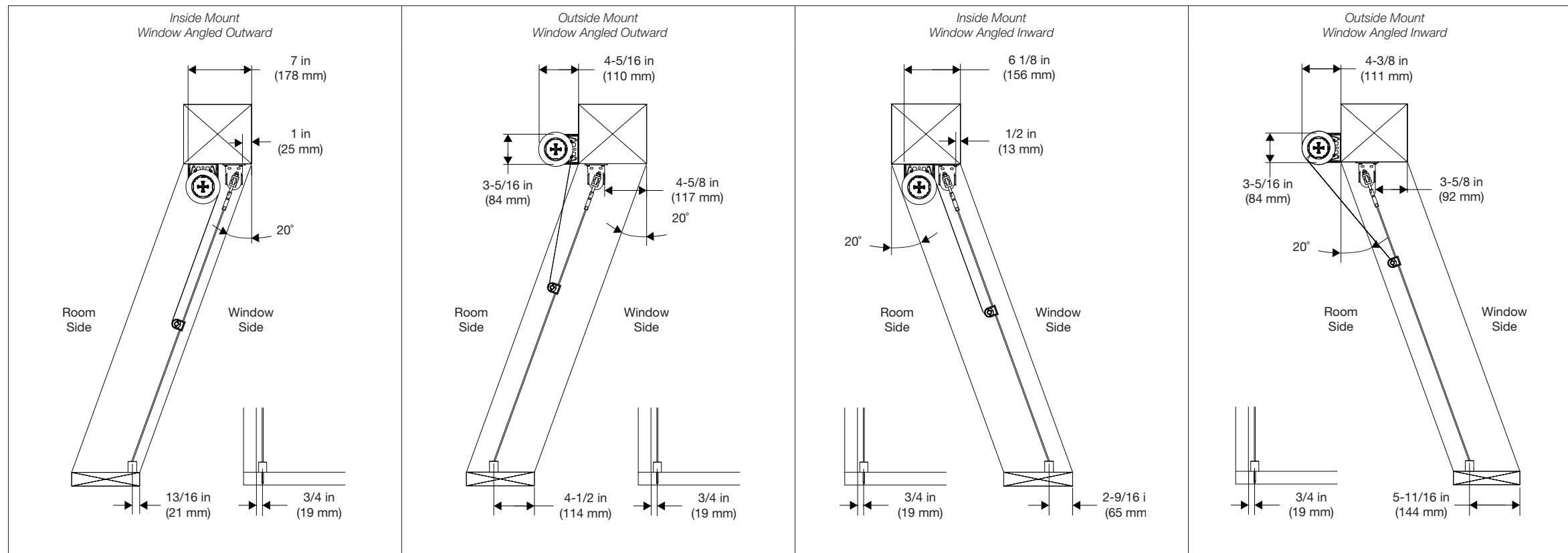

As of the date of manufacture, the product has been tested and found to comply with specifications for CE marking.



The product warranty can be found at www.crestron.com/warranty.

The specific patents that cover Crestron products are listed at www.crestron.com/legal/patents.

Certain Crestron products contain open source software. For specific information, please visit www.crestron.com/opensource.

Crestron, the Crestron logo, and Crestron Toolbox are either trademarks or registered trademarks of Crestron Electronics, Inc. in the United States and/or other countries. Other trademarks, registered trademarks, and trade names may be used in this document to refer to either the entities claiming the

marks and names of their products. Crestron disclaims any proprietary interest in the marks and names of others. Crestron is not responsible for errors in typography or photography.

This document was written by the Technical Publications department at Crestron.

©2018 Crestron Electronics, Inc.

Crestron Electronics, Inc.
15 Volvo Drive, Rockleigh, NJ 07647
Tel: 888.CRESTRON
Fax: 201.767.7576
www.crestron.com

Installation Guide - DOC. 8247A

(2050608)

01.18

Specifications subject to change without notice.